

CHEVALIER®

FTC-1320V

TRAVELING COLUMN TYPE HIGH SPEED VERTICAL MACHINING CENTER

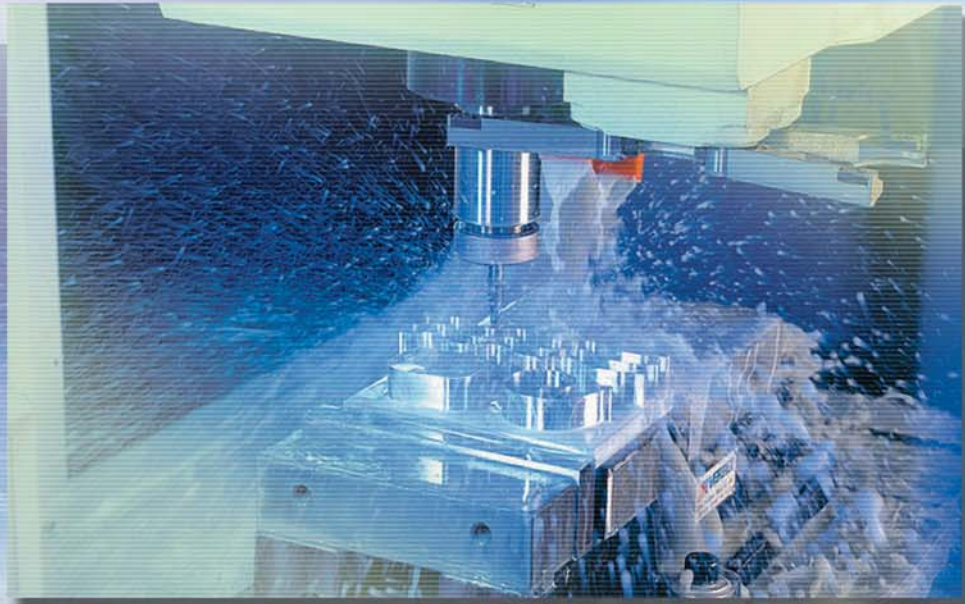

FTC-1320V

1 MACHINE FEATURES

- All three axes use self-grease -lubricated guideways system, this kind of lubrication system can protect environment as there is no used oil disposal problem.
- To increase the safety during machining, the machine base is one-piece casting with slope design and equipped with large volume coolant flow surrounding the machine base for fast chips removal.

Traveling Column

Type High Speed

Vertical Machining Center

AS FAST AS YOU CAN GET IN A MACHINE THIS SIZE!

- Spindle Speed
15000rpm
- X,Y Rapids
1417ipm(36m/min)
- Z Rapid
1181ipm(30m/min)
- Tool-to-tool
0.8secs.
- Table Index
2secs.



FTC-1320V

Traveling Column Type High Speed Vertical Machining Center

FTC-1320V
CHEVALIER

FANUC OiMC Control

1. Minimum increment 0.001mm (0.0001")
2. Absolute/incremental programming G90/G91
3. Decimal point programming
4. Automatic recognition on EIA/ISO code
5. Positioning G00
6. Linear Interpolation G01
7. Circular Interpolation & Radius command G02, G03
8. Cutting feedrate F4-Digit command

9. Dwell G04
10. Rapid traverse override F0,25%, 50%, 100%
11. Cutting feedrate override 0%~150%
12. Parts program storage 40m
13. Registered programs 63
14. Part program editing
15. Rigid tapping
16. Canned cycle
17. Absolute type encoder
18. Emergency stop

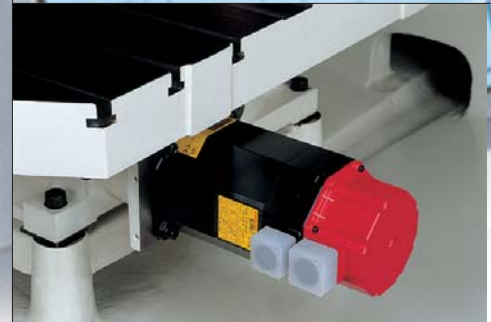

cycle time:2min12sec



Increase in Productivity!

With special holding fixture, during machining on one side of table, operator can load and unload workpiece on the other side of table. Thus the machining efficiency can be increased over 50% than traditional type of machine.

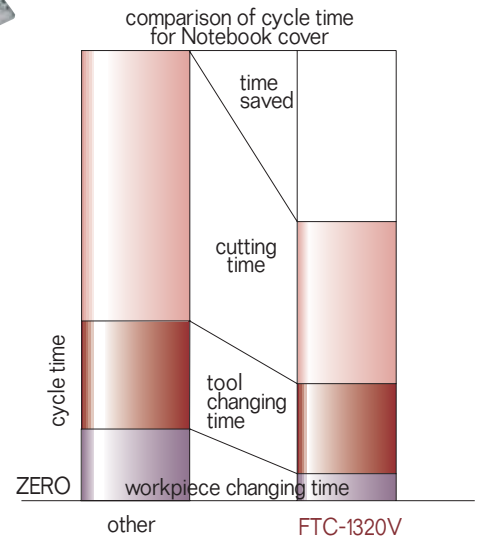

FTC-1320V

3 MACHINE CONSTRUCTION



1 3 Axes Traveling Column Design

- For high speed machining that requires super fine finish. Ballscrews are mounted close to the machining point for maximum rigidity, and to minimize the influence of the ballscrew after long period of operation.

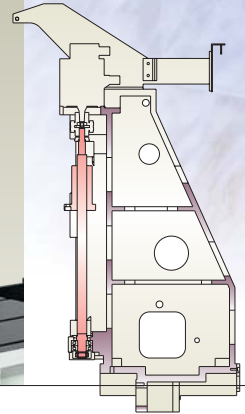

2 Turntable

- Servo motor directly drives the turntable, makes acceleration and deceleration smooth. Turntable exchange quickly, takes only 2 sec. Completely improve drawbacks happened in traditional pneumatic & hydraulic type. The center cover of the turntable reserved 6 holes for air connecting. With special holding fixture, operator can load and unload the workpieces, during machining at the other side of table to enhance the working efficiency of manpower and machine.

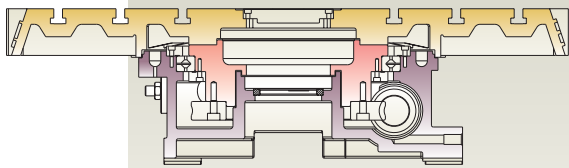

3 Small Footprint and rigid Machine base

- 61"x132"(1550x3353mm) total floor space requirement perfect for Factory Automation and Machining Cell. One piece machine base is designed through 3D-Dynamic Simulation Analysis for highest stability and rigidity.

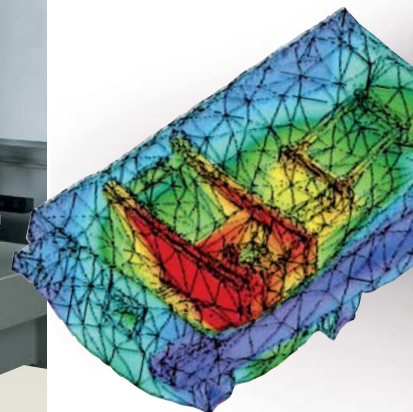
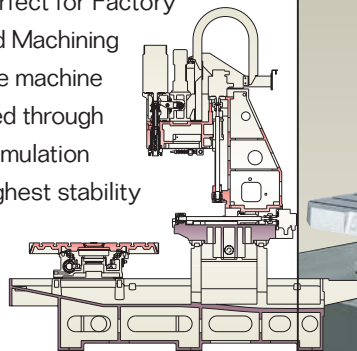

2610-00013000

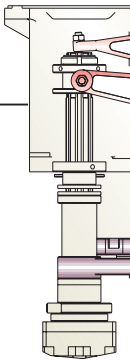

4

1

2

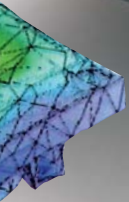

4

Directly Mounted Spindle(15000rpm/option 20000rpm)

■ Spindle is supported by 4pcs angular contact ball bearings mounted at 15° angle for increased rigidity and high speed machining accuracy. The DBB type combination increased torque ability. Spindle and spindle motor are directly mounted to eliminate noise and reduce the vibration during high speed operation.

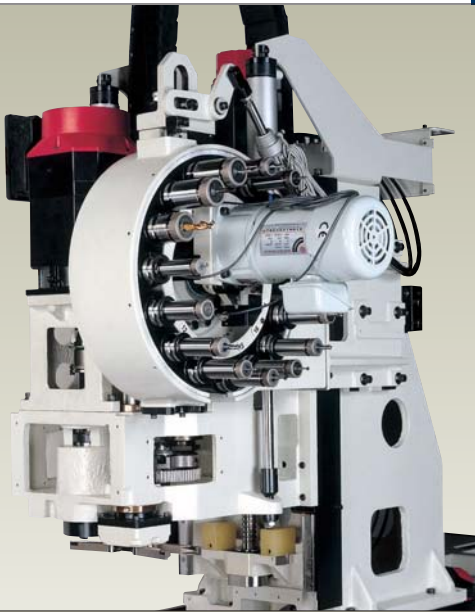
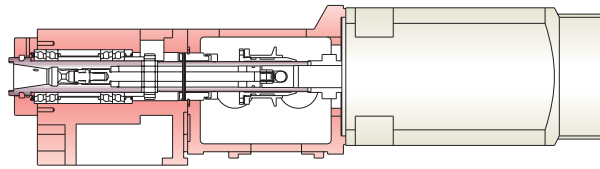

Instant Chip Disposal

■ Cutting chips are disposed by large volume coolant flow around the whole machine base. A Grunfos pump, with 500 l/min(60HZ) coolant flow, is used for chips removal.



Cam Type Tool Changer (patented)

■ Bi Directional Access with random tool selection at shortest distance, resulting with 0.8 secs tool change time in all machining conditions.

Machining Capacity

unit:mm
1mm=0.03937inch

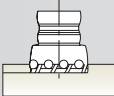
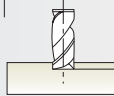
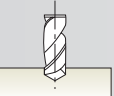
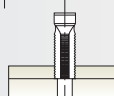
machining material	Facing		End mill	
	S45C	 <p>Cutting amount cm³/min(inch³/min): Cutting width(mm)xCutting depth(mm)xFeed rate (mm/min) 26(1.7):40 x 2 x 325</p>	 <p>Cutting amount cm³/min(inch³/min): Cutting width(mm)xCutting depth(mm)xFeed rate (mm/min) 9(0.6):20 x 2 x 225</p>	
machining material	Drill		Tap	
	S45C	 <p>Tool diametermm(inch) x Feed rate mm(inch)/rev Ø14 (Ø0.55)x 0.3(0.01)</p>	 <p>Tool diameter mm(inch) x Feed rate mm(inch)/rev M12x1.75(7/16)</p>	

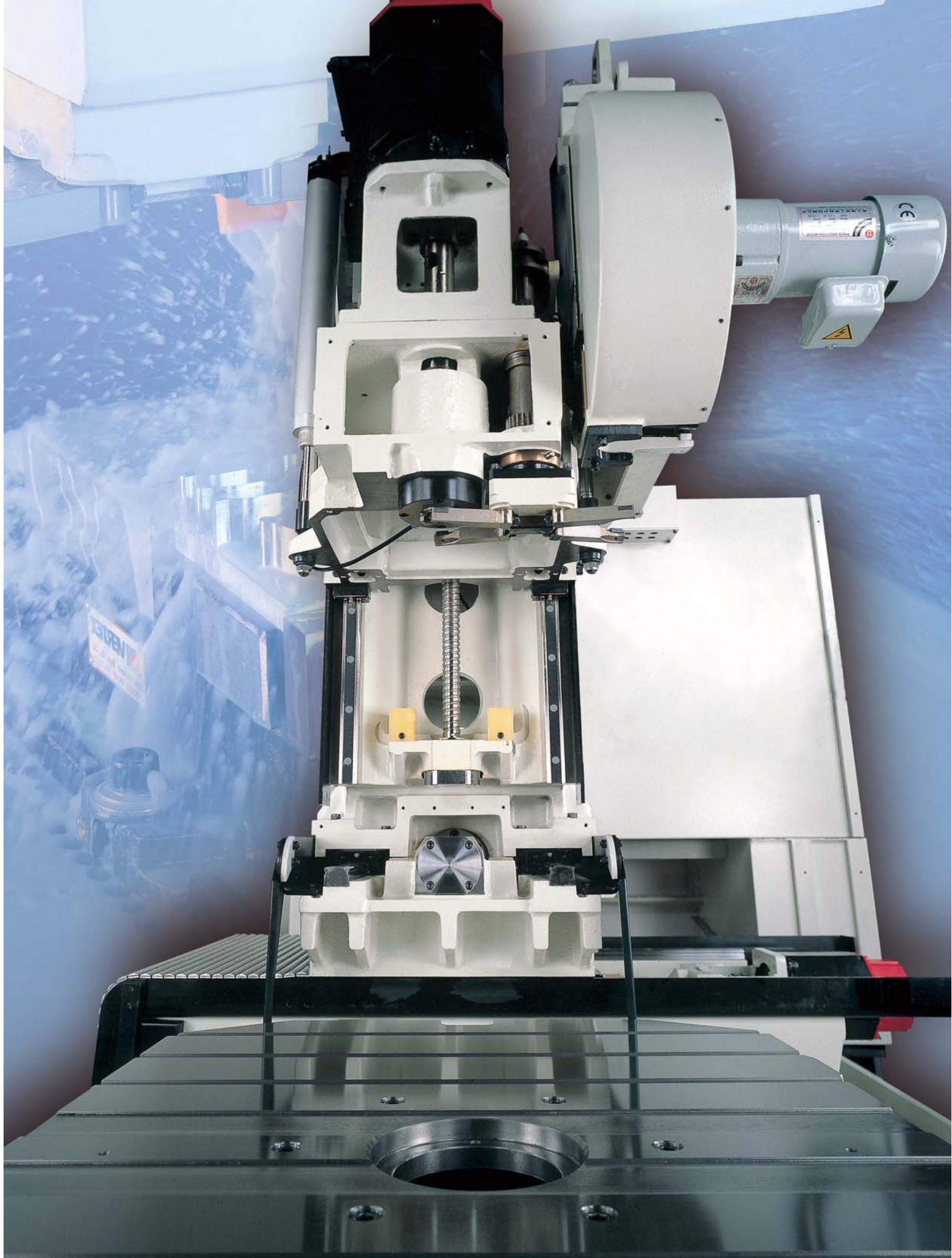

FTC-1320V

7

EXAMPLE



Example: Earphone
Dimension: 120x90x38mm
Material: NAK-80
Tool: R4 Ball-nosed end mill
Spindle speed: 12000rpm
Feed rate: 1000mm/min

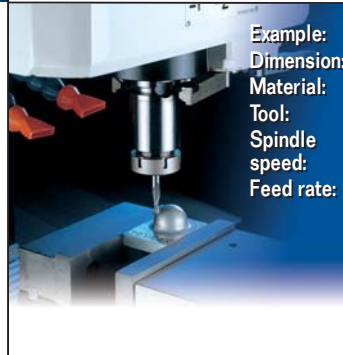

Example: Hemisphere
Dimension: 65x50x31mm
Material: Aluminum alloy (A6061 T6)
Tool: R4 Ball-nosed end mill
Spindle speed: 12000rpm
Feed rate: 500mm/min

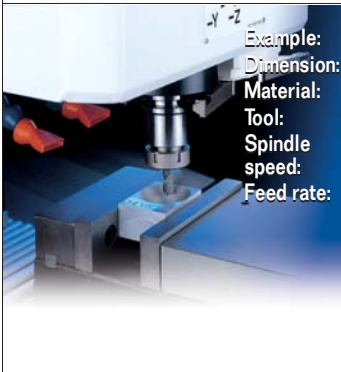

Example: Inner cone
Dimension: 65x50x31mm
Material: Aluminum alloy (A6061 T6)
Tool: ø6 End mill
Spindle speed: 15000rpm
Feed rate: 1000mm/min

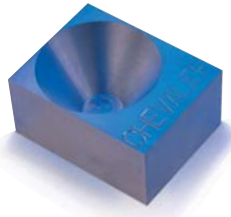

Example: Thin-walled spiral
Dimension: 140x100x32mm
Material: Aluminum alloy (A6061 T6)
Tool: ø8 End mill
Spindle speed: 15000rpm
Feed rate: 3000mm/min

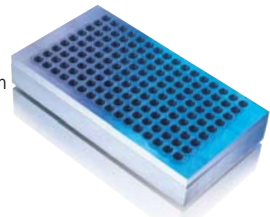

Example: Boring
Dimension: 190x100x30mm
Material: Aluminum alloy (A6061 T6)
Tool: ø7.8 Drilling/ø8 End mill
Spindle speed: 2000/3000rpm
Feed rate: 200/150mm/min
Holes: 144 holes
 (Drilling depth 20mm/15mm)
 6.7sec/15sec/per hole

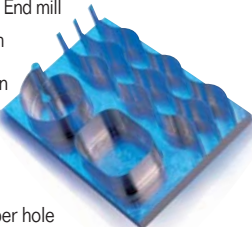

Example: Tapping
Dimension: 80x80x15mm
Material: Aluminum alloy (A6061 T6)
Tool: M6
Spindle speed: 6000rpm
Feed rate: 6000mm/min

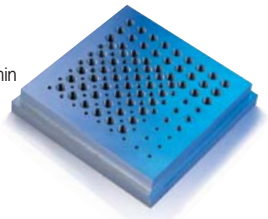

Example: Watch case
Dimension: 37x32x13mm
Material: Brass (C1100 1/2H)
Tool: ø6 End mill (rough milling)
 R0.5 Ball-nosed end mill (finishing)
Spindle speed: 15000rpm
Feed rate: 500mm/min

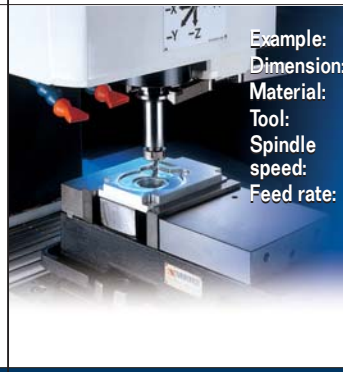

Example: Hard disk
Dimension: 146x101.5x20mm
Material: Aluminum alloy (A6061 T6)
Tool: ø20 End mill/ø10 Boring tool
Spindle speed: 3000, 6000, 18000rpm
Feed rate: 900, 1800, 80mm/min

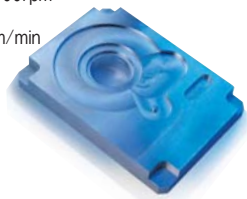

APPLICATION SAMPLE

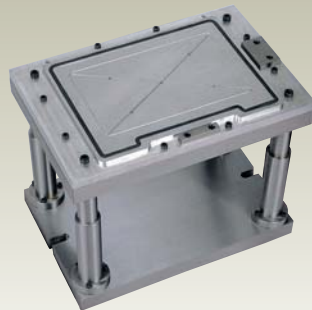

Fixture for notebook case
 (Vacuum attachment)
 Patented



Notebook case

TOOL SHANK & PULL STUD

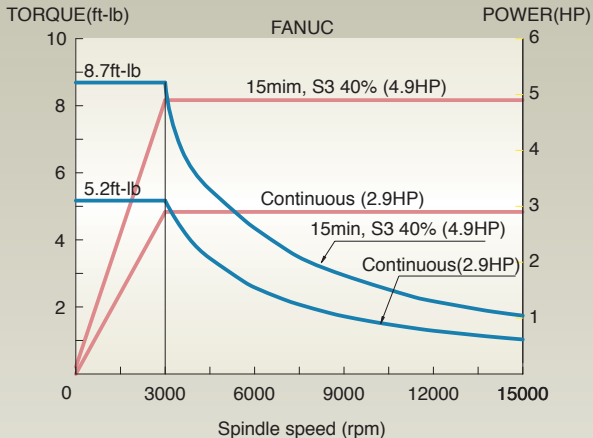
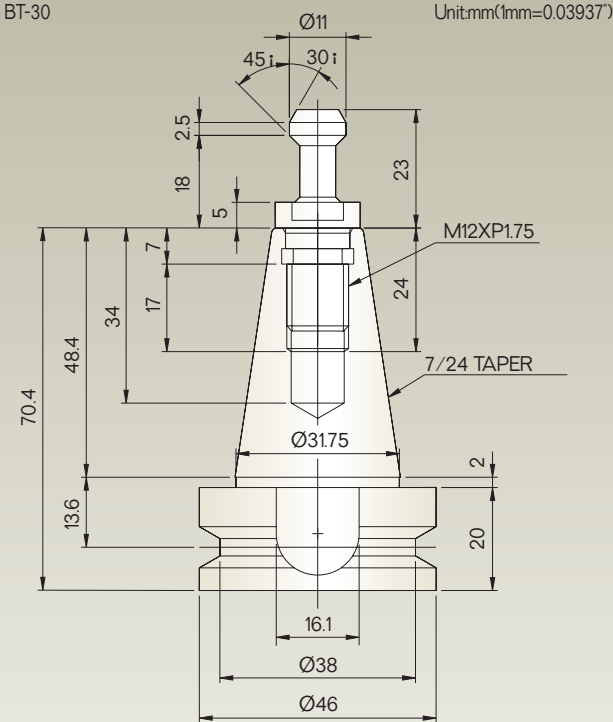

DIMENSION DRAWING

Unit:mm(1mm=0.03937)

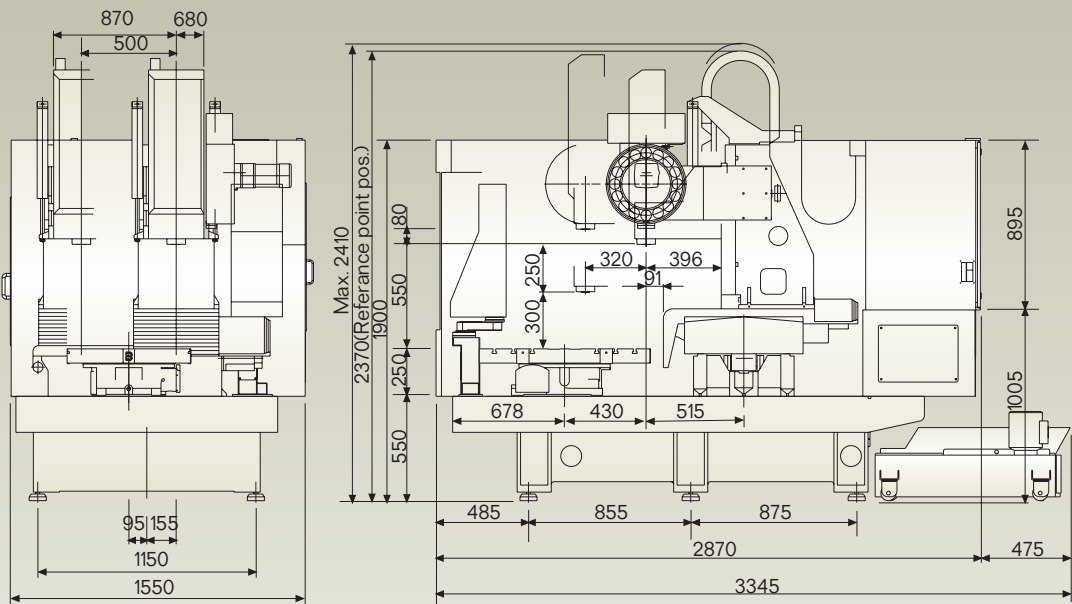

GENERAL SPECIFICATION

Standard Accessory

1. Leveling bolts & pads
2. Enclosed splash guard
3. Coolant system
4. Standard tools
5. 16 stations ATC
6. Turntable
7. Safety switch of automatic door
8. Alarm lamp
9. Pilot lamp
10. Mitsubishi 64M or FANUC 0iMC control

Optional Accessory

1. Pull stud
2. Coolant gun
3. Portable MPG instead of fixed MPG
4. Hinge type chip conveyor
5. Scraper type chip conveyor
6. Riser block

※ Note: The manufacturer reserves the right to modify the design, specifications, mechanisms... etc. of the machine without prior notice. All the specifications shown above are just for reference.

Description	FTC-1320V
Travels	
X axis	19.7" (500mm)
Y axis	12.6" (320mm)
Z axis	9.8"(250mm)+3.1"(80mm)(ATC)
Spindle Nose to Table	11.8"~24.8"(300~630mm)
Spindle Center to Column	15.6" (397mm)
Feed rate	
Rapid traverse rate	X,Y: 1417 IPM(36m/min) Z: 1181 IPM(30m/min)
Cutting Feed rate	39.4~393.7 IPM(1~10m/min)
Feed-rate motor	1.34HP (1kw)
Spindle	
Spindle dia°—taper	Ø1.57"(Ø40mm) x BT30
Spindle speed	150~15,000rpm
Spindle speed change	S5-5digit
Max. taping rpm	6000rpm
Spindle motor	3.0/5.0HP(2. 2/3. 7kw)
(Continuous/15 min.)	
ATC/MG	
Tool magazine capacity	16+1
Max. tool length x dia	7.87" x Ø2.36"(200 x Ø60mm)
Max. tool weight	4.4 lbs(2kg)
Tool Shank/ Pull stud	MAS BT30/P30T-1
Tool load/unload	Double arm swing type
Tool selection	Random
ATC motor	1/4HP(0.2kw)
Tool Magazine (MG) motor	1/4HP(0.2kw)
Table	
Table Size	25.6"x14.4"(650mmx365mm)
Max. table load	264 lbs(129kg)for each surface
Motor	1.34HP(1kw)
Noise	80dB(A)or less
Vibration	0.00016"(4µm)or less
Floor space	61" x 131.7"(1550mm x 3345mm)
Machine height	94.9"(2410mm)
Machine weight	8157 lbs (3700kg)
Power required	15kVA
Air pressure	59~73.5lb/in ² , 95 gal/min 4~5kgf/cm ² , 360cm ³ /min
Accuracy	VDI/DSG 3441 JIS 6338
Positioning	P0.014mm P0.005/300mm(0.0002"/11.8")
Repeatability	PS0.010mm(0.000394") PS ±0.003mm(±0.00012")



Grinder

VMC

Lathe

CHEVALIER MACHINERY INC.

9925 Tabor Place Santa Fe Springs, CA 90670 U.S.A
 TEL:(562)903-1929 FAX:(562)903-3959
<http://www.chevalierusa.com>
 E-mail:info@chevalierusa.com